

## Filiera tipo **SPE** *per trafilatura in barre*

**SPE type die**  
for drawing bars



**Filière type SPE** pour  
tréfilage en barres



**Hileras tipo SPE** para  
trefilado en barras



**Волока типа SPE** для  
волочения прутков



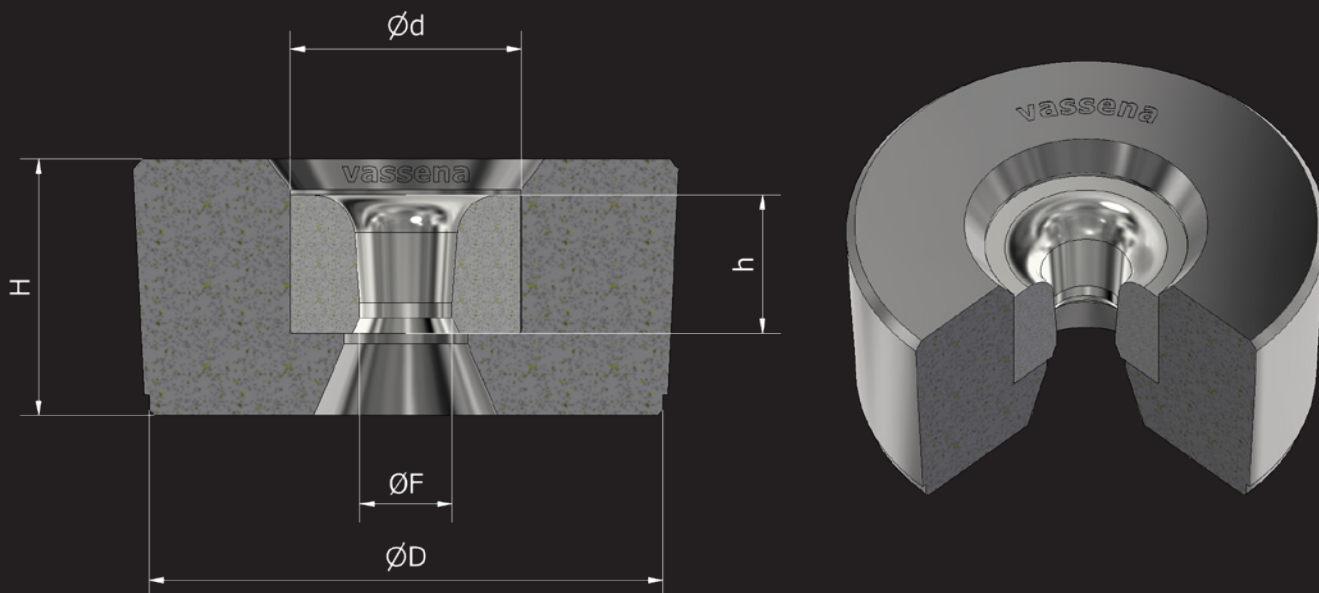

code	size	d x h	D x H	$\varnothing F$
FS370	1°	20x18	80x40	2.00 - 5.00
FS380	2°	25x20	80x40	5.01 - 8.00
FS390	3°	30x24	80x40	8.01 - 10.00
FS400	4°	35x24	80x40	10.01 - 13.00
FS410	5°	40x27	100x50	13.01 - 16.00
FS420	6°	45x27	100x50	16.01 - 19.00
FS430	7°	50x30	120x55	19.01 - 22.00
FS440	8°	55x30	120x55	22.01 - 25.00
FS450	9°	60x30	150x60	25.01 - 28.00
FS460	10°	65x30	150x60	28.01 - 32.00
FS470	11°	70x33	180x65	32.01 - 36.00
FS480	12°	75x33	180x65	36.01 - 40.00
FS490	13°	80x33	180x65	40.01 - 44.00
FS500	14°	85x33	180x65	44.01 - 48.00
FS510	15°	90x36	220x70	48.01 - 52.00

IT	EN	FR	ES	RU
Filiera usata su macchine continue o dotate di spintore. A richiesta può essere fornita con montatura conica o cilindrica.	Die used on continuous machines or machines fitted with pusher. Cylindrical or conical casing can be supplied on request.	Filière utilisée sur des machines continues ou munies de pousseur. Livrables, sur demande, avec monture conique ou cylindrique.	Hilera utilizada en máquinas continuas o equipadas con empujador. A petición, se puede suministrar con montura cónica o cilíndrica.	Данная волока предназначена для использования на станках непрерывного действия или с толкателем. По запросу возможна поставка с конической или цилиндрической обоймой.